

# DuroLift

## HAND PALLET TRUCK 2500 - (Short Forks)

### Features

**Durable Hydraulic Pump**

**Fork Frame in heavy gauge steel**

**Central Fingertip Controls with the handle in any position**



### Specifications

<b>Stock Number</b>	<b>DL1</b>
<b>Capacity - kg</b>	<b>2500 kg</b>
<b>Fork Lift Height - Minimum</b>	<b>85 mm</b>
<b>Fork Lift Height - Maximum</b>	<b>200 mm</b>
<b>Individual Fork Width</b>	<b>160 mm</b>
<b>Overall Fork Width</b>	<b>550 mm</b>
<b>Forks Length</b>	<b>800 mm</b>
<b>General Description</b>	<b>Heavy Duty hydraulic pump</b>

**Price** **£ 210 ex. works**

( All Prices exclude Delivery and V.A.T. & are Subject to Change Without Notice )

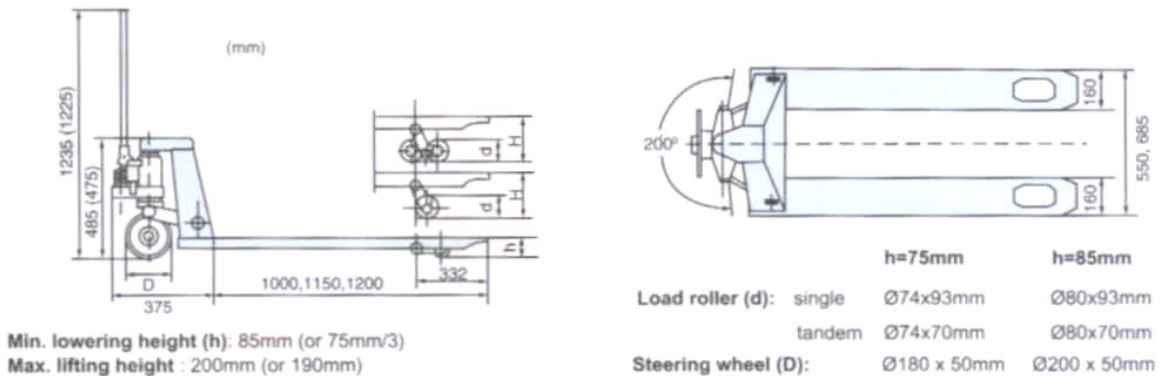
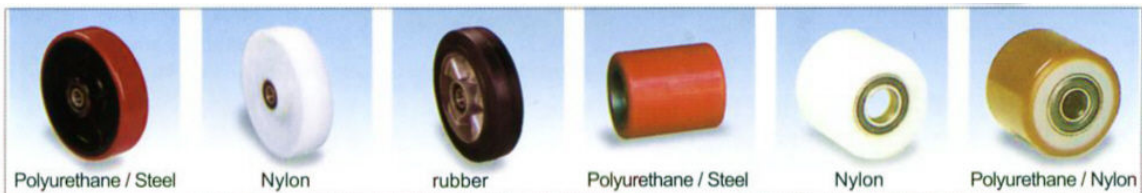

# DuroLift